

CR1 TiFit tips

1. Start by measuring Seat Width (A)

- Remember, this chair is meant to be rigid and ultra-lightweight with no width adjustment.
- Stay as tight as possible for optimal positioning and push efficiency.

2. Next, find the table with the desired Seat Depth (B): 13"-19" at 1" increments.

3. Identify your client's optimal Front Seat-to-Floor Height (C) and Rear Seat-to-Floor Height (D).

- Subtract measurement (D) from measurement (C) to find the Seat Slope.
 - Example:
 - Front Seat-to-Floor Height = 19"
 - Rear Seat-to-Floor Height = 16.5"
 - $19 - 16.5 = 2.5$ " Seat Slope

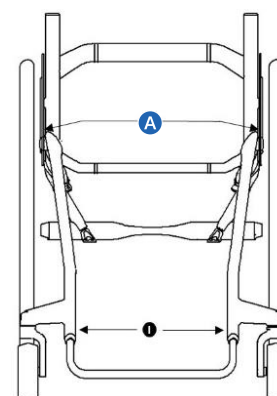

4. Using the 2nd column of the Seat Depth table, identify the Seat Slope closest to your client's optimal configuration to determine Frame Type (1, 2 or 3).

5. In that same row, input your client's optimal Front Seat-to-Floor Height (C) in the fillable box. You can specify it to the closest 1/4" increment.

Note: you can add or subtract 1/4" as needed to the Front Seat-to-Floor Height (C) to get as close as possible to your client's desired Rear Seat-to-Floor Height (D).

6. Custom Frame Depth

- By default, the frame bend will start 1" in front of the seat sling (equivalent to 1/2" in front of the seat sling on other TiLite frame styles).
- If you need additional space between the seat sling and the frame bend, you can do 1/2" increments up to 2" additional custom frame depth as noted below:
 - 13"-17" seat depths can get up to 2" of custom frame depth.
 - 18" seat depth can get up to 1" of custom frame depth.
 - Custom frame depth is not available for 19" seat depth.

7. Front End (I)

- A 2.1" Taper (footrest width is 4.2" shorter than seat width) is standard for all CR1 chairs.

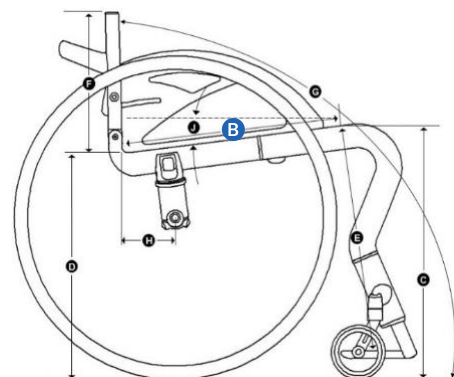

8. Front Angle

- a. An 85° front angle bend is standard for all CR1 chairs.

9. Seat-to-Footrest (E)

- a. Measure from the front edge of the seat sling to the top middle of the footrest.
- b. Measurement must be 1" to 3" shorter than Front Seat Height (C) in ¼" increments.
- c. Remember, the CR1 has the ability to adjust the footrest height ±1" upon delivery to find your Balanced Ride.

10. Seat Back Angle (G)

- a. Measured from the front of the backrest post to the floor in 1° increments.

11. Centre of Gravity (H)

- a. Due to its design and materials, the CR1 has a lighter than normal front-end compared to other TiLite models which will affect the overall feel when selecting this measurement. We recommend a less aggressive COG placement when going to the CR1 from another chair model.
- b. We recommend considering other factors such as custom frame depth, backrest height, footrest type, rear wheel type, accessories, and clothing when making this decision.
- c. Remember, the CR1 has the ability to adjust COG ±1" upon delivery to find your Balanced Ride.